

## »BISON« E 620 TECHNICAL DATA



### UNDER REALISTIC CONDITIONS AT THE AIRPORT:

With an aircraft tow tractor including 4-wheel-drive and equal weight distribution on both axles, on wet concrete (friction coefficient  $\mu=0.57$ ), 1% apron inclination, and aircraft engines running during pushback.

In case of different requirements please contact us for new calculations based on your specific operation conditions.

<b>OPERATION WEIGHTS</b>	+ 17 t   21 t   26 t   28 t max.
<b>MTOW</b>	+ 250 t
<b>DRAWBAR PULL INSTALLED</b>	+ 205 kN



FIND OUT MORE  
»BISON« FAMILY

MADE FOR YOUR MISSION

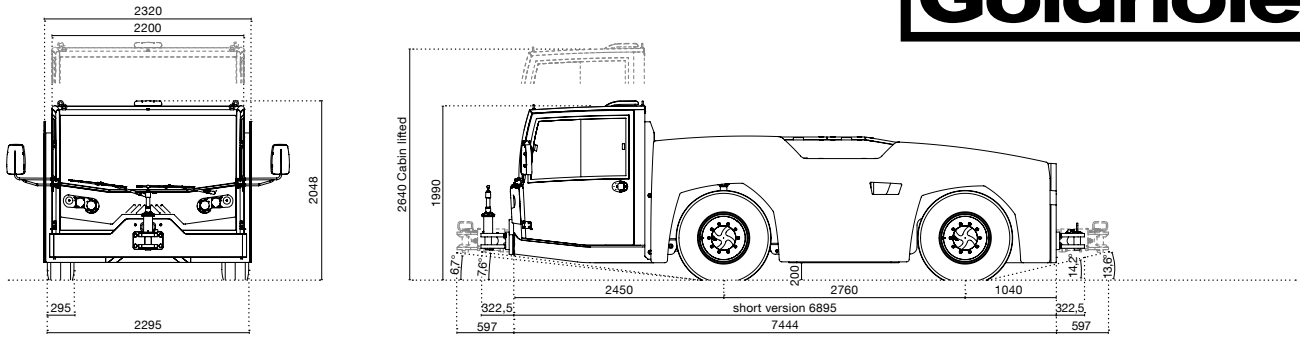

## 609 Nm | 115 kW



### 400 V LITHIUM-ION BATTERY

Maximum installed Battery capacity 175 kWh (5x35 kWh)  
Integrated charging system power of 22 kW



### TURNING RADIUS

+ 6,027 mm

### TRANSMISSION

+ 6 gears forward/3 reverse  
+ Draw bar pull limiter dependent on selected aircraft type  
+ ZF automatic full-power-shift transmission with integrated torque converter, manual and automatic gear-shifting mode

### AXLES

+ Driven steering axles with planetary drives in the wheel hubs  
+ Front and rear axles driven by full-power-shift transmission through joint shafts

### STEERING SYSTEM

+ Standard 4-wheel steering  
+ Front-wheel and crab steering (optional)  
+ Emergency steering pump

### TIRES

+ Front + rear 310/80R 22.5

### BRAKES

+ Fully hydraulic 2-circuit safety internal brake system  
+ 1-circuit failsafe parking brake  
+ Emergency parking-brake release by electrical emergency pump

### HYDRAULIC SYSTEM

+ Brakes and steering system  
+ Cabin-lift and jacks

### CABIN

CABLESS + Full-width elevating, all-steel front cabin  
BASIC CABIN + Comfortable driver's and passenger's seat with safety belts (third seat optional)  
+ Adjustable steering column  
+ Interior lights  
OPEN CAB + Wiper-washer system for front  
OPTION + Rear-view mirrors (1 inside, 2 outside)  
+ Front tow-hitch mirror  
CLOSED CAB + Lockable doors with sliding windows  
OPTION + Cabin/windscreen ventilation and heating  
+ Heated rear window with screen wiper



### OPTIONS EXAMPLES

+ Cushioned tow hitch  
+ Fully airconditioning system  
+ Second passenger seat  
+ Electrically adjustable and heated rearview mirror  
+ Rear-view camera  
+ Central lubrication system  
+ Remote Control  
+ 4 integrated hydraulic jacks

### GOLDHOFER AIRPORT TECHNOLOGY

Location: Donaustrasse 95, 87700 Memmingen/Germany  
Location: Parkstrasse 19-21, 73760 Ostfildern/Germany  
Web: www.goldhofer.com, E-Mail: info@goldhofer.com

### SALES

Telephone: +49 8331 15-343,  
E-Mail: sales-airporttechnology@goldhofer.com

### SERVICE AND SPARE PARTS

Telephone: +49 8331 962 99 99, Fax: +49 8331 15-247  
E-Mail: service-airporttechnology@goldhofer.com

**MADE FOR YOUR MISSION**